



Systems of accessories for electrical installations used for residential, tertiary and industrial applications. The system consists of fasteners for pipes and cables, cable fittings, accessories for rigid pipes (RK Series) and flexible conduit (DF Series). The system include also a wide variety of cable ties (52FS Range) and terminal blocks (44 Range).

| | | | |
|-----------------------|---|----------------------------|--------|
| Colour | Grey RAL 7035 | IP degree | IP44 |
| Material | Flexible polymer | For external conduits (mm) | 32 |
| Mounting hole Ø (mm) | 37 | Glow Wire Test | 750 °C |
| Operating temperature | -5 +60 °C | Electrocod | 21221 |
| Standard | EN 61386-1 - EN 60670-1 (as applicable) | | |

BEHAVIOUR WITH CHEMICAL AND ATMOSPHERIC AGENTS

| Saline solution | Solvents | | | Mineral oil | UV rays |
|-----------------|---------------|--------------------|---------------|-------------|-----------|
| | Hexane | Benzol | Acetone | | |
| Resistant | Not resistant | Limited resistance | Not resistant | Resistant | Resistant |

DIMENSIONAL

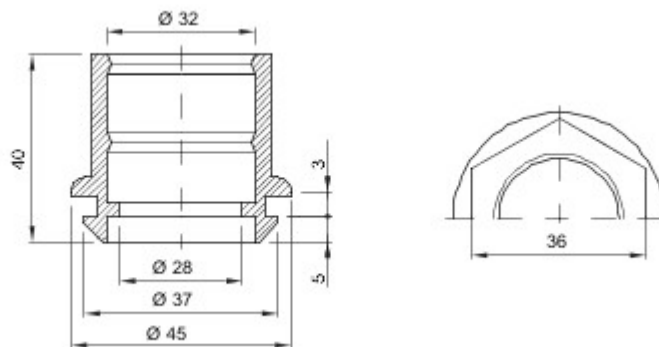

TECHNICAL SYMBOLOGY

IP

IP44

GWT

750 °C

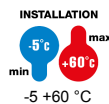

-5 +60 °C

STANDARDS/APPROVALS



GEWISS S.p.A. Via A. Volta, 1
24069 Cenate Sotto - Bergamo - Italy
tel. +39 035 94 61 11 fax +39 035 94 69 09

www.gewiss.com
sat@gewiss.com
Last update 18/02/2021

Data, measures, designs and pictures are shown only as informative purposes, and could be changed without previous notice